

PRORIL

50Hz

GOMAX Series, these non-clog pumps employ a single-channel enclosed impeller to efficiently and reliably transfer 76mm diameter solids without clogging. GOMAX series pumps are suitable for commercial and industrial wastewater applications.

Sewage Pump

GOMAX 4220/6220

Single Channel Pump



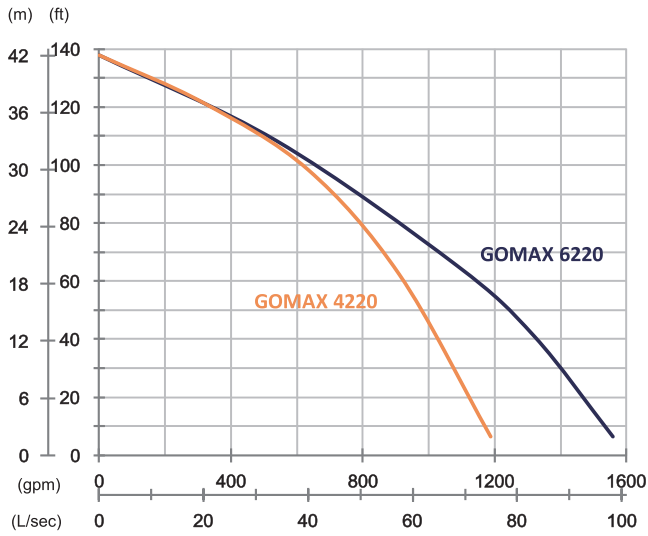

	GOMAX 4220	GOMAX 6220
OUTPUT	22 kW (30 HP)	22 kW (30 HP)
OUTLET	4" (100 mm)	6" (150 mm)
SOLID PASSAGE	76 mm	76 mm
Weight	256 kg	262 kg
HEAD	Rated: 30 m Max: 42 m	Rated: 20 m Max: 42 m
FLOW	Rated: 40 L/s Max: 75 L/s	Rated: 68.3 L/s Max: 98.3 L/s

Pump Type	Electric Submersible Pumps	
Motor	Phase	3-Phase
	Type	Induction Motor
	Poles	4 Pole (1450 rpm)
	Insulation	Class F
	Protector	Miniature Thermal Sensors
	Starter	Star-Delta
Lubricant	Food Grade (ISO VG32)	
Specs.	Impeller Type	Single Channel
	Shaft Seal	Double Mechanical Seal
		Silicon Carbide VS Ceramic/Carbon
	Bearings	C3 Shielded ball bearings
Cable	H07RN-F	
	10 m or longer upon request	
Materials	Pump Casing	Gray Iron
	Impeller	Gray Iron
	Motor Frame	Gray Iron
	Motor Shaft	Stainless Steel
	Mouth Ring	Copper Alloy
Max. Liquid Temperature	40°C (104°F)	
Max. Submersion Depth	20 m (66 ft)	
pH Range	pH 5 - pH 8	
Guide Rail	GRN-04	

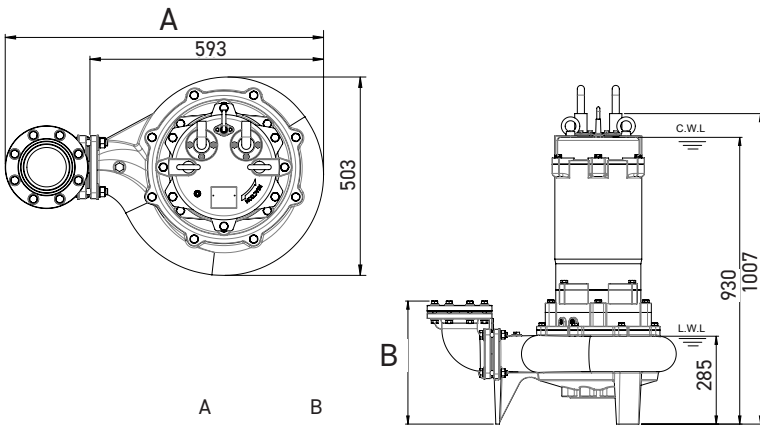

	A	B
GOMAX 4220	808	382
GOMAX 6220	867	455

unit : mm
C.W.L : Continuous running water level
L.W.L : Lowest running water level